

Model No. : OEM-JT12/DZ25-3L



Product Introduction

Easy operation, change tube rapidly. The house material is PPS (polyphenylene sulfite). 304 stainless steel rollers. DZ25 pump head use 2.4mm wall thickness tube, the flow rate range is 0.211-3600mL/min. This pump head is suitable for high viscous liquid which include granule and floc. It also suitable for high pressure request. New cartridge structure design, can use the special connector, connect low cost tubing outside the pump head to save cost; also can use flexible tube clamp, meet hygiene requirement.

Typical Application

- 1.This pump head is suitable for high viscous liquid which include granule and floc.
- 2.It is also suitable for high pressure request.

Flow Data

Pump Head	Housing Material		Tubing		Speed Range(rpm)	Flow Rate (mL/min)	Weight (kg)
	Body	Tubing Clamp Material	Tubing Sizes	ID×Wall Thickness			
DZ25-3L	PPS	PP	15#	4.8×2.4(mm)	0.1-600	0.211~1264	0.5
			24#	6.4×2.4(mm)		0.385~2310	
			35#	7.9×2.4(mm)		0.508~3050	
			36#	9.6×2.4(mm)		0.6~3600	

Motor Specification

Model No.	Motor type	Power supply	Speed(rpm)	Speed error	Working environment
OEM-JT12	AC speed motor	AC220V(standard), AC110V(optional)	43-430	≤+10%	0-40C, 80%RH



Dimension Drawing (Unit:mm)

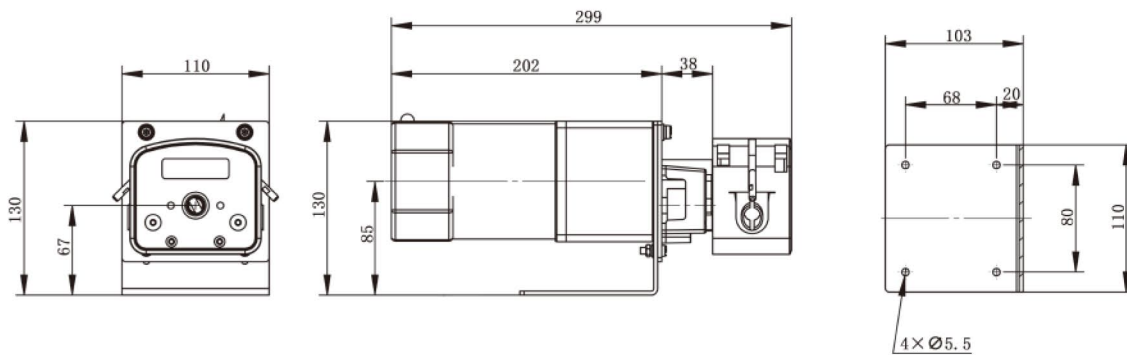

Tubing Installation Procedure



A. Lift both side levers, take off the upper block.



B. Put the tubing with cartridge or connector into pump housing.



C. Install the upper block, put down the levers to lock the block.