

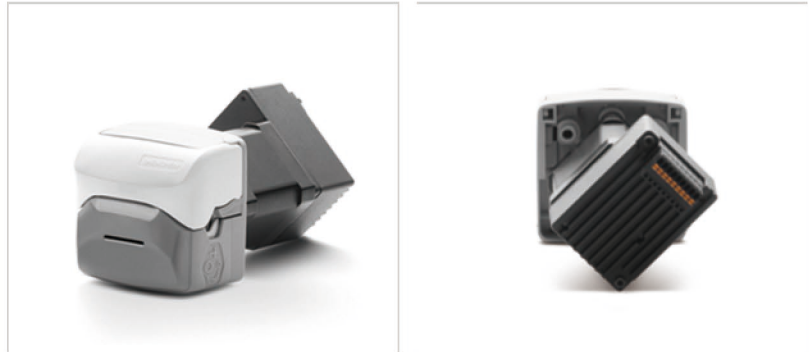

### Technical Specification

Model No. : OEM-KTB012  
 Pump head: KT15 pump head  
 Roller number: 4  
 Suitable tubing: Silicone and Pharmed tube  
 Motor type: Integrated closed-loop stepper motor  
 Motor speed: 0.1-600  
 Flow rate range: 0.0033-560.04mL/min  
 Motor life: >10000hours



### Flow Data

Pump Head	Channel number	Suitable Tubing		mL/r	Speed (rpm)	Flow Rate(mL/min)	Weight(kg)
		Tubing	ID×Wall thickness(mm)				
KT15	Single Channel	13#	0.8×1.6	0.033	0.1~600	0.0033~19.97	0.096
		14#	1.6×1.6	0.156		0.0156~93.42	
		19#	2.4×1.6	0.286		0.0286~171.6	
		16#	3.1×1.6	0.477		0.0477~286.32	
		25#	4.8×1.6	0.933		0.0933~560.04	

Note: Flow data measured with water and silicone tubing. This may vary considerably depending on the tube type, use period, ambient temperature, and lot tolerances, etc.

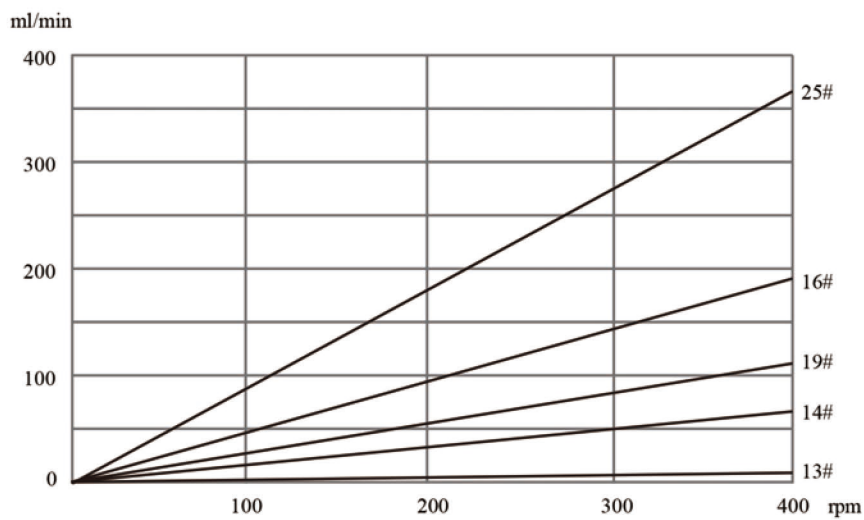



### Motor Specification

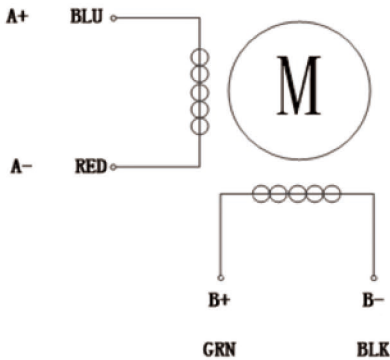

Speed range	0.1-600
Flow rate range	0.0033-560.04mL/min
Speed control	Pulse signal control speed, RS485
Subdivisions	1/16(Default), can be set through RS485
Motor type	Integrated closed-loop stepper motor
Power supply	DC24V, ≥36W
Logic input voltage	DC5V
Working environment	0-40°C, 80%RH

### Dimension Drawing (Unit:mm)

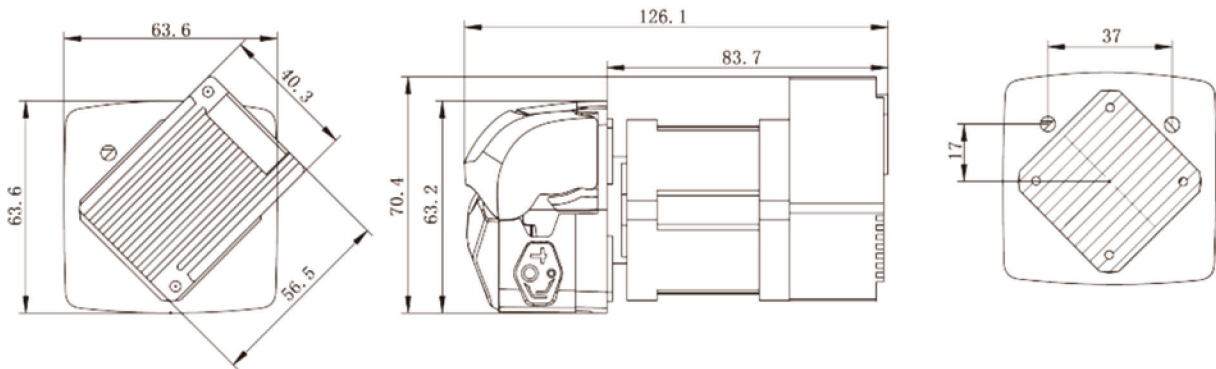

### Tubing Installation Procedure



1. Lift the flip top of the pump head to open the pump head.

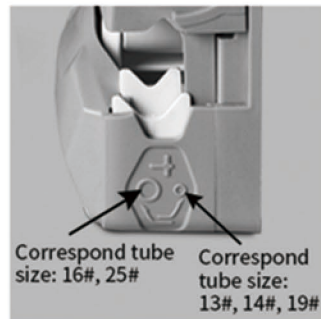

2. Adjust the tube holder to the position corresponding to the installed size.



3. Put the tubing into the pump head.



4. Close the flip top of the pump head downward to complete the installation.

## Tube Holder Position



**Inner position for small tubing: 13#, 14#, 19#**

**Outer position for large tubing: 16#, 25#**

Note: If the tube holder is in its inner position, for small tubing (13#, 14#, 19#), and larger tube (16#, 25#) is used, flow and tube life will be decreased.

If the tube holder is in its outer position, for large tubing (16#, 25#), and smaller tube (13#, 14#, 19#) is used, there is a risk that the tube will wander in the pump head and it may rupture.

## Change The Tube Holder Position



Place the pointed device (such as a ball-point pen) pointing down into the small depression pictured here.

Press down the tube holder to the bottom, slid the pointed device to right or left side, then release the pressure, the jaw rises into its correct alignment.

If it does not rise, repeat the procedure.

Adjust the tube holder on the other side of the pump head in the same way.