

Multichannel Pump Head

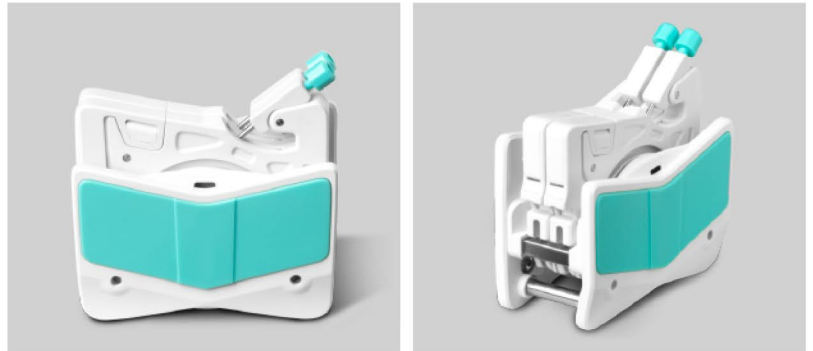

Model No. : AMC
Flow Rate : 0.0002-60mL/min



Product Features

- Flexible positioning mechanism, users can install and remove cartridge easily.
- Flexible pressure tube design to extend the service life of the tube.
- Stepless adjustment of pressure tube gap to improve the transmission accuracy between channels.
- 304 stainless steel roller assembly, two types roller structures: 6 rollers and 10 rollers.
- Multichannel, low flow rate transferring, compact structure, suitable for instrument supporting.

Model Number

AMC1, AMC2, AMC3, AMC4, AMC5, AMC6, AMC8, AMC10, AMC12

Typical Application

- Support blood sugar analytical device.
- Support ammonian analytical instrument.

Dimension Drawing (Unit:mm)

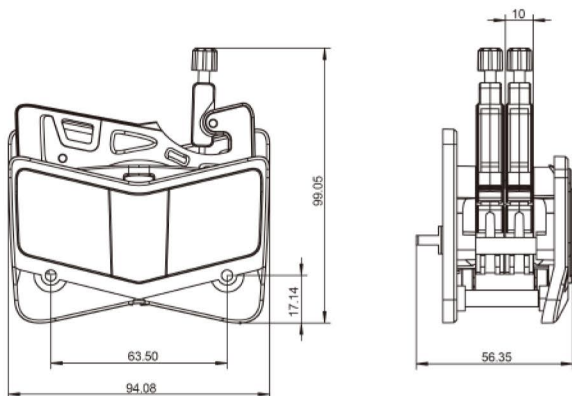

Note: Increasing or reducing one channel, the pump head size need to increase or reduce the thickness of one cartridge.



Flow Rate

AMC Series pump head Technical Specifications									
Channel number	1	2	3	4	5	6	8	10	12
Cartridge material	POM/PVDF								
Rollers number	10 rollers, 6 rollers								
Tubing	Speed	Flow rate of pump head with 10 rollers (mL/min)	Flow rate of pump head with 6 rollers (mL/min)	Tubing Max.Pressure(Mpa)					
				Intermittent	Continuous				
1×1	0.1~150rpm	0.0050~7.55	0.0062~9.36	0.1	0.1				
2×1		0.0183~27.52	0.0220~33.06						
2.4×0.8		0.0254~38.13	0.0319~47.81						
3×1		0.0323~48.38	0.0434~65.17						
0.13×0.86		0.0002~0.29	0.0002~0.31						
0.19×0.86		0.0003~0.44	0.0003~0.46						
0.25×0.86		0.0005~0.76	0.0005~0.80						
0.51×0.86		0.0013~2.00	0.0014~2.05						
0.89×0.86		0.0030~4.47	0.0031~4.65						
1.14×0.86		0.0061~9.16	0.0065~9.74						
1.42×0.86		0.0125~18.75	0.0142~21.28						
2.06×0.86		0.0197~29.60	0.0234~35.17						
2.79×0.86		0.0286~42.86	0.0372~55.77						

Tubing Installation



1. Easily press the elastic lock arm mechanism to open the cartridge.



2. After the cartridge is disconnected, install the tube, the two adjacent tube stoppers determine a working position.



3. Press the cartridge to make the cartridge to enter the working position.



4. Pull the pressing device to enter the pressure tube state.



5. Installation finished.



Invention Patent

AMC obtained  EU Appearance patent.



Appearance patent No.: 008005789-0001