



Model No. : OEM-B29/EasyPump



Flow Data

Pump Head	Tubing	ID×Wall thickness(mm)	mL / r	Flow Rate(mL/min) (0.1-600rpm)	Tubing Max.Pressure(Mpa)		Weight(kg)
					Intermittent	Continuous	
Single Channel EasyPump I/III	13#	0.8×1.6	0.053	0.0053~32	0.27	0.17	0.6
	14#	1.6×1.6	0.27	0.027~162			
	19#	2.4×1.6	0.55	0.055~330			
	16#	3.1×1.6	0.933	0.093~560	0.24	0.14	
	25#	4.8×1.6	1.967	0.197~1180			
	17#	6.4×1.6	3.333	0.333~2000			
	18#	7.9×1.6	4.3	0.430~2580			
Single Channel EasyPumpII/ IV	15#	4.8×2.4	1.8	0.180~1080	0.27	0.17	
	24#	6.4×2.4	2.733	0.273~1640			
	35#	7.9×2.4	3.833	0.383~2300	0.24	0.14	
	36#	9.6×2.4	5.167	0.517~3100			
Dual Channel EasyPump V/VI	13#	0.8×1.6	0.0053	0.0053~32	0.27	0.17	
	14#	1.6×1.6	0.27	0.027~162			
	19#	2.4×1.6	0.55	0.055~330			
	16#	3.1×1.6	0.933	0.093~560	0.24	0.14	
	25#	4.8×1.6	1.967	0.197~1180			



Motor Specification

Model No.	OEM-B29/EasyPump
Speed range	0.1-600rpm
Flow rate range	0.0053-3100mL/min
Motor type	57stepper motor
Motor phase number	2
Motor step angle	1.8°
Motor phase voltage	1.5V
Motor phase current	3.0A
Working environment	0-40°C, 80%RH

Dimension Drawing (Unit:mm)

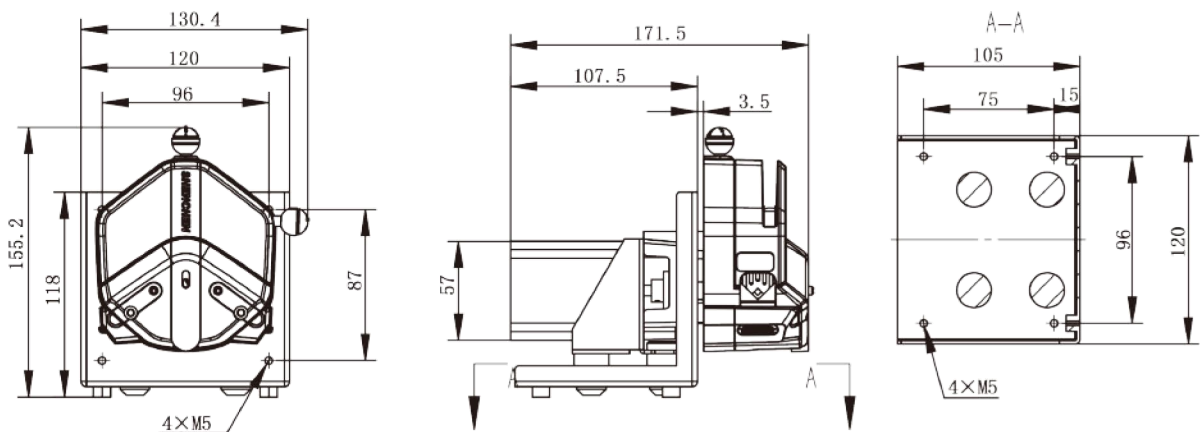

Tubing Installation Procedure



1. Turn the knob anticlockwise 180°, open the upper block.



2. Turn the rubbing wheel to adjust the lower tube clamp position, according to the tubing size.



3. Put the tube between rollers and upper block, tighten up the tubing lightly.

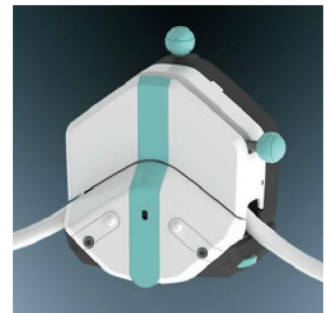

4. Turn the knob clockwise 180°, put the upper block back to original position, fasten the tube.