



Product Features

Model No. : **OEM-KTJ001/002/003**

Pump head: KT15 pump head

Roller number: 4

Suitable tubing: Silicone and Pharmed tube

Motor type: AC synchronous motor

Motor speed: 15rpm, 30rpm, 60rpm

Flow rate range: 0.0033-55.98mL/min

Motor life: ≤ 1000hours



Flow Data

Pump Head	Channel number	Suitable Tubing		mL/r	Speed (rpm)	Flow Rate(mL/min)	Weight(kg)
		Tubing	ID×Wall thickness(mm)				
KT15	Single Channel	13#	0.8×1.6	0.033	0.1~600	0.0033~19.97	0.096
		14#	1.6×1.6	0.156		0.0156~93.42	
		19#	2.4×1.6	0.286		0.0286~171.6	
		16#	3.1×1.6	0.477		0.0477~286.32	
		25#	4.8×1.6	0.933		0.0933~560.04	

Note: Flow data measured with water and silicone tubing. This may vary considerably depending on the tube type, use period, ambient temperature, and lot tolerances, etc.

Technical Specification

Power supply	AC220V/50Hz
Motor type	AC synchronous motor
Power consumption	OEM-KTJ001/002: 14W; OEM-KTJ003: 20W
Motor speed	OEM-KTJ001: 15rpm(±10%)
	OEM-KTJ002: 30rpm(±10%)
	OEM-KTJ003: 60rpm(±10%)
Pump head	KT15
Condition temperature	0-40°C
Environment humidity	≤80%RH, No condensation
Working environment	Keep away from heating equipment, avoid dust, oil mist corrosive gas and strong vibration places.

Wire Connection

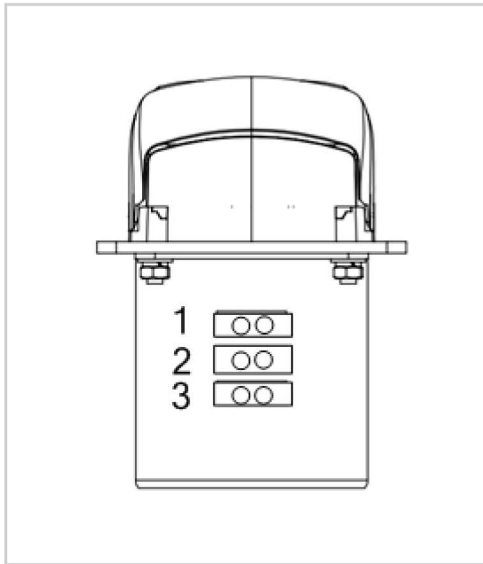

- Input AC220V
- Pin 1 and Pin 2 connect to power supply, the motor runs clockwise (CW).
- Pin 2 and Pin 3 connect to power supply, the motor runs counterclockwise (CCW).

Dimension Drawing (Unit:mm)

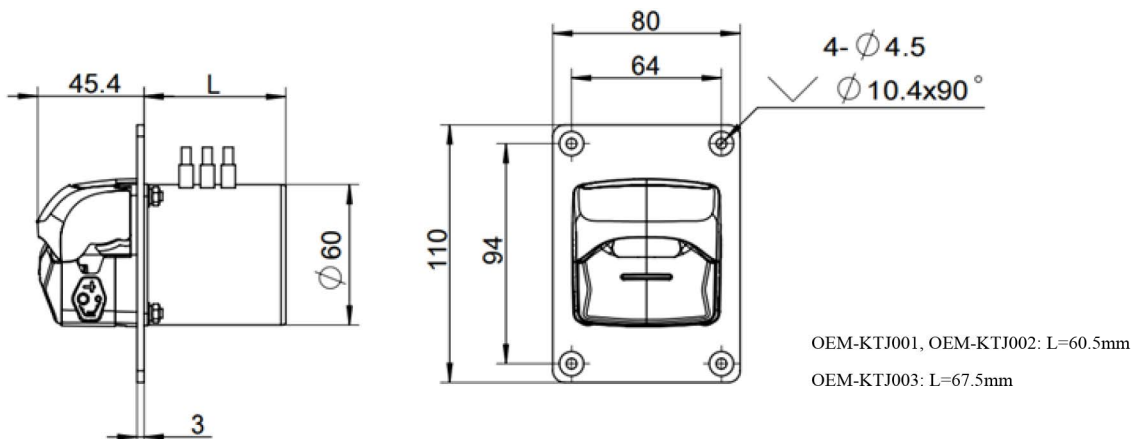

Tubing Installation Procedure



1. Lift the flip top of the pump head to open the pump head.

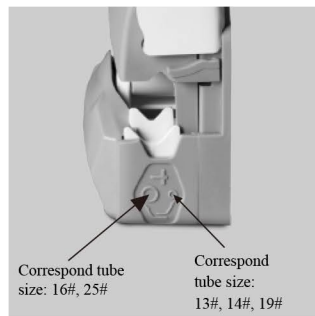

2. Adjust the tube holder to the position corresponding to the installed size.



3. Put the tubing into the pump head.



4. Close the flip top of the pump head downward to complete the installation.

Tube Holder Position



Inner position for small tubing: 13#, 14#, 19#

Outer position for large tubing: 16#, 25#

Note: If the tube holder is in its inner position, for small tubing (13#, 14#, 19#), and larger tube (16#, 25#) is used, flow and tube life will be decreased.

If the tube holder is in its outer position, for large tubing (16#, 25#), and smaller tube (13#, 14#, 19#) is used, there is a risk that the tube will wander in the pump head and it may rupture.

Change The Tube Holder Position

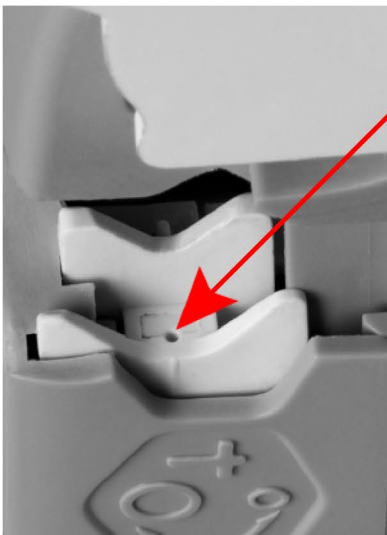

Place the pointed device (such as a ball-point pen) pointing down into the small depression pictured here.

Press down the tube holder to the bottom, slid the pointed device to right or left side, then release the pressure, the jaw rises into its correct alignment.

If it does not rise, repeat the procedure.

Adjust the tube holder on the other side of the pump head in the same way.