

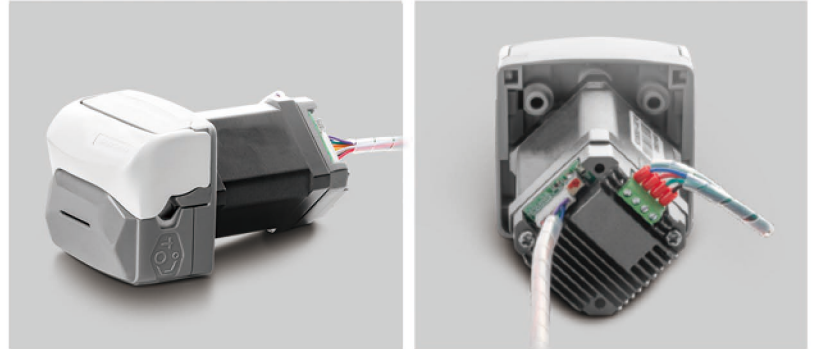

Technical Specification

Pump head: KT15 pump head
 Roller number: 4
 Suitable tubing: Silicone and Pharmed tube
 Motor type: 42 stepper motor
 Motor speed: 0.1-400rpm
 Flow rate range: 0.0033-373.2mL/min
 Motor life: >10000hours



Flow Data

Pump Head	Channel number	Suitable Tubing		ml/r	Speed (rpm)	Flow Rate(mL/min)	Weight (kg)
		Tubing	ID×Wall thickness (mm)				
KT15	Single Channel	13#	0.8×1.6	0.033	0.1~400	0.0033~13.20	0.096
		14#	1.6×1.6	0.156		0.0156~62.40	
		19#	2.4×1.6	0.286		0.0286~114.40	
		16#	3.1×1.6	0.477		0.0477~190.80	
		25#	4.8×1.6	0.933		0.0933~373.20	

Note: Flow data measured with water and silicone tubing. This may vary considerably depending on the tube type, use period, ambient temperature, and lot tolerances, etc.

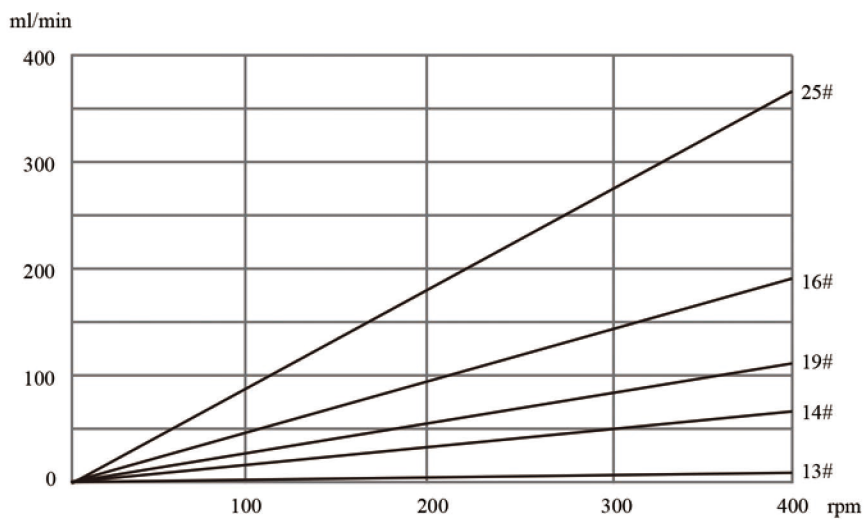

Motor Specification

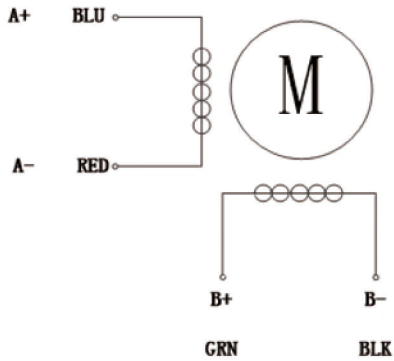

Speed range	0.1-400rpm
Flow rate range	0.0033-373.2mL/min
Outer control	Passive switch signal control start/stop and direction
Speed control	External potentiometer speed control 0-5V, 0-10V, 4-20mA
Motor type	42 stepper motor
Power supply	DC24V
Working environment	0-40°C, 80%RH

OEM-KTB002	42-60 stepper motor with M42/4-20mA control module
OEM-KTB003	42-60 stepper motor with M42/0-5V control module
OEM-KTB004	42-60 stepper motor with M42/0-10V control module
OEM-KTB005	42-60 stepper motor with M42/USB fixed speed control module
OEM-KTB006	42-60 stepper motor with M42/RP potentiometer speed control module
OEM-KTB007	42-60 stepper motor with M42/RP-A external potentiometer speed control module
OEM-KTB008	42-60 stepper motor with PM26
OEM-KTB009	42-60 stepper motor with M42/RS232 communication control module
OEM-KTB010	42-60 stepper motor with M42/RS485 communication control module

Dimension Drawing (Unit:mm)

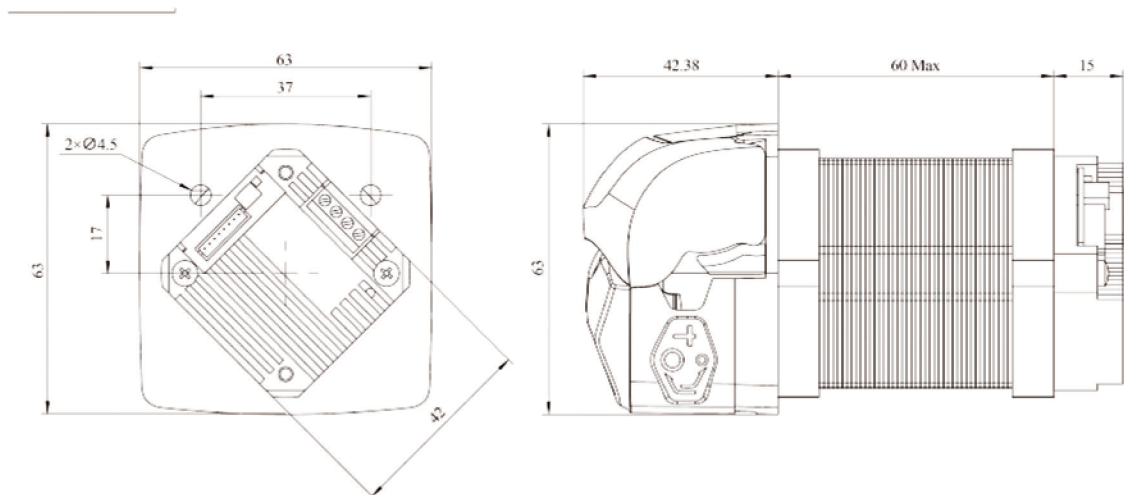

Tubing Installation Procedure



1. Lift the flip top of the pump head to open the pump head.

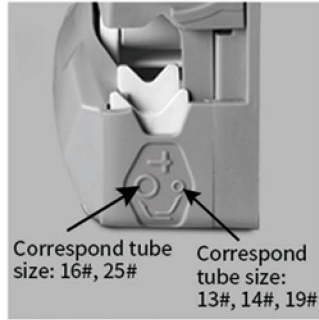

Correspond tube size: 16#, 25#
Correspond tube size: 13#, 14#, 19#

2. Adjust the tube holder to the position corresponding to the installed size.



3. Put the tubing into the pump head.



4. Close the flip top of the pump head downward to complete the installation.

Tube Holder Position



Inner position for small tubing



Outer position for large tubing

Inner position for small tubing: 13#, 14#, 19#

Outer position for large tubing: 16#, 25#

Note: If the tube holder is in its inner position, for small tubing (13#, 14#, 19#), and larger tube (16#, 25#) is used, flow and tube life will be decreased.

If the tube holder is in its outer position, for large tubing (16#, 25#), and smaller tube (13#, 14#, 19#) is used, there is a risk that the tube will wander in the pump head and it may rupture.

Change The Tube Holder Position



Place the pointed device (such as a ball-point pen) pointing down into the small depression pictured here.

Press down the tube holder to the bottom, slid the pointed device to right or left side, then release the pressure, the jaw rises into its correct alignment.

If it does not rise, repeat the procedure.

Adjust the tube holder on the other side of the pump head in the same way.