

Model No. : OEM-KDB302



Flow Data

Pump Head	Tubing	ID×Wall thickness(mm)	Speed (rpm)	Flow Rate(mL/min) (3 rollers)	Flow Rate(mL/min) (4 rollers)	Tubing pressure resistance(Mpa)		Weight (kg)
						Continuous	Intermittent	
KD15	13"	0.8x1.6	0.1-600	0.0083-50.3	0.0079-47.37	0.27	0.17	0.37
	14"	1.6x1.6		0.0281-168.4	0.0267-160.37			
	19"	2.4x1.6		0.0613-367.97	0.0544-326.13			
	16"	3.2x1.6		0.1006-603.5	0.0942-565.47	0.24	0.14	
	25"	4.8x1.6		0.2243-1345.83	0.2103-1262			
	17"	6.4x1.6		0.3297-1978.1	0.2915-1748.93			
	18"	7.9x1.6		0.5047-3027.97	0.4483-2690			
KD25	15"	4.8x2.4	0.2513-1507.6	0.1979-1187.55	0.27	0.17		
	24"	6.4x2.4	0.3912-2346.95	0.2909-1745.5				

Motor Specification

Speed range	0.1-600rpm
Flow rate range	0.0079~3027.97mL/min
Speed control method	External input pulse frequency speed regulation
Subdivision setting	The four-position dip switch setting (default setting: 16 subdivisions).
Current setting	Adaptive current
Motor type	57 stepper motor
Working power supply	DC18~50V(Recommended 36V), ≥80W
Logical input voltage	DC5V
Working environment	0-40°C, <80%RH no condensation



Dimension Drawing (Unit:mm)

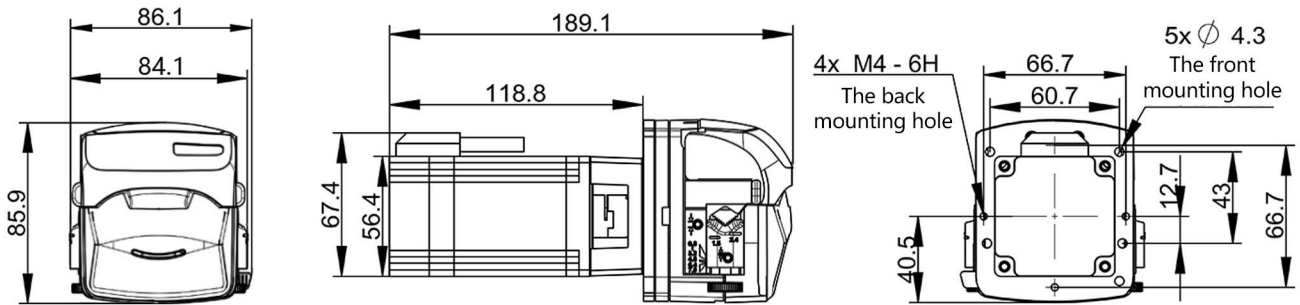

Tubing Installation Procedure



1. Lift the flip top of the pump head to open the pump head.

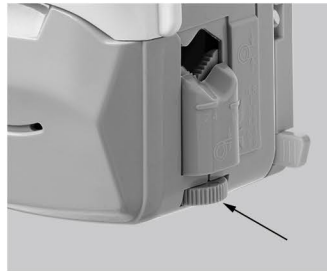

2. Rubbing wheel adjustment



3. Put the tubing into the pump head.



4. Close the flip top of the pump head downward to complete the installation.