

Spring Pump Head

UC20



57 Stepper motor
spring-like structure

Product Introduction

UC20 spring pump head is widely used for medical dialysis equipment. Transparent protective cover, can observe the working situation anytime; uncover signal output, stop working when uncover to ensure safety; Elastic roller assembly, running smoothly; manual lever help install the tube, and can finish liquid circulation when power down unexpectedly; support stepper motor ,DC motor, AC motor and sevro motor.

Typical Application

| Medical dialysis equipment.

Dimension Drawing (Unit: mm)

Supporting instrument 57 stepper motor

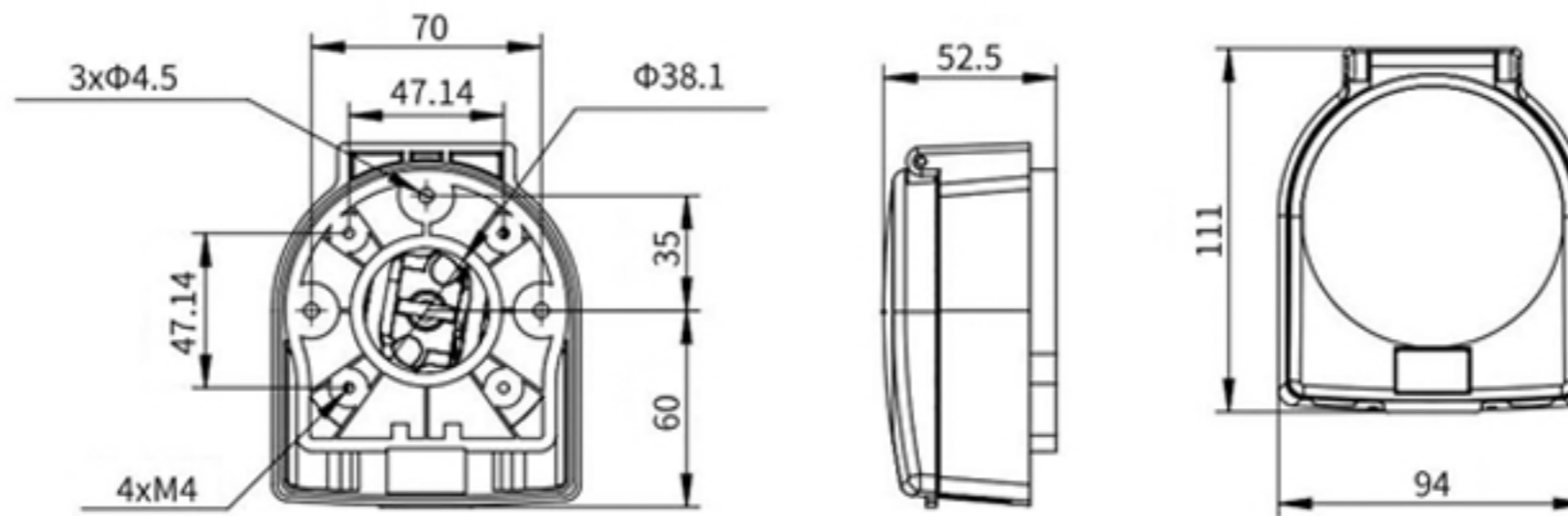

Tubing Installation Procedure



1. Press the pipe clamp, put the tube into the U shaped groove.



2. Put the tube between the two guide posts. Hold the spanner, rotate the wheel body.



3. Press the pipe clamp, put the tube into the U shaped groove.



4. Installation is finished.

Technical Specifications

Model	Housing Material		Rollers assemble construction	Tubing		Speed Range (rpm)	Flow Rate (mL/min)	Weight(kg)
	Base	Protecting cover		Size	ID×Wall(mm)			
UC20	PSF	PC	spring-like structure	Medical dialysis tube	8×2	0.1-200	0.3910-782	1.42

